



SPEC NO.	SP07CT99300-010	ISSUED DATE	2004/09/02	PUBLISHED BY
PRODUCT NAME	GPS RECEIVER/CT-9930	VERSION	01	
		PAGE	2/11	

INDEX

Item No.	Contents	Page
1.0	Cautions	3
2.0	Absolute Maximum Rating	4
3.0	Normal Operating Conditions	4
4.0	Electrical Characteristics	4
5.0	Module Specification	5
6.0	Time to First Fix (TTFF)	6
7.0	Module Interface	6
8.0	Communication Specification	6
9.0	Recommend Antenna Specifical	7
10.0	Dimension	8
11.0	GPS Receiver Module Configuration	9
12.0	Reference	11

SPEC NO.	SP07CT99300-010	ISSUED DATE	2004/09/02	PUBLISHED BY
PRODUCT NAME	GPS RECEIVER/CT-9930	VERSION	01	
		PAGE	3/11	

1.0 Cautions

GPS (Global Positioning System) is a satellite-based navigation system. In an unobstructed clear view of the sky, GPS works anywhere in the world, 24 hours a day.

GPS is developed and operated by the government of United States. Under the policy of the government, the degradation in accuracy shall occur without prior warnings, and sometimes satellites don't transmit signal due to adjustment, test, and orbital revision.

Please be aware that the performance of the GPS receiver module does not warrant against the above factors.

Also, please note:

1. products such as motors, computer, and RF devices, which emit high levels of magnetic field and interference that may cause the performance of the GPS unit to drop.
2. the optimal position during automobile applications is on the roof top of the vehicles. If the GPS unit is to be placed inside the car, be certain to avoid coverage by metal objects for optimal performance.

(Position Accuracy)

Position data and position accuracy are affected or degraded by the satellite geometry, electric magnetic interference, and multipath.

(Equipment)

The high frequency noise will interfere with signal receiving. The high frequency noise within the receiver frequency band, 1575Mhz \pm 10MHz, will affect the receiver quality. Also, because of the mixer and modulation, the low frequency noise will be increased by several times. If this increased frequency drops into the 1575MHz \pm 10MHz band, it will also affect the receiver quality.

Another warning should be notified. GPS receiver modules should not be placed close to heat and fans. Drastic changes in temperature will degrade the signal receiving strength even when operating within the operation temperature. Crystal and crystal oscillator on PCB ASSY should be kept away from the cooling fan.

(Power)

If the impedance of the power terminal is too high (power cable too thin and over 10 cm long), then S/N will be degraded. Please insert condenser (above 47 μ F) into cable terminal to remove ripple.

(Operation)

Static electricity will destroy IC and erase backup data. Wear anti static electricity bundle while you are using the GPS Receive Module).

Besides static electricity, plugging in or out the connector while power on will cause initialization. Make sure this is performed under power-off condition.

SPEC NO.	SP07CT99300-010	ISSUED DATE	2004/09/02	PUBLISHED BY
PRODUCT NAME	GPS RECEIVER/CT-9930	VERSION	01	
		PAGE	4/11	

(Antenna)

In order to strengthen the sensitivity for car navigation, GPS antenna is suggested to mount on a flat place around 80x80mm.

(Warranty)

If the product fails within one year after the date of delivery while it has been used properly it will be replaced or repaired free of charge.

(Environmental conditions)

The product should be suitably installed or shielded so that it should not be affected by high frequency (1575.42MHz \pm 10MHz) noises from other devices like CPUs. Don't allow the airflow from the cooling fan to come directly to the quartz crystal oscillator in the receiver module.

2.0 Absolute Maximum Ratings

Note: This module is not intended to operate under the conditions listed in Absolute Maximum Ratings. Continuous operation under these conditions or exceeding the maximum ratings may result in permanent damage to this device.

Symbol	Parameter	Min	Typ	Max	Units
V _{CC}	Module Supply Voltage	- 0.3	5.0	9	V
V _I	Input Voltage	- 0.3		V _{CC}	V
T _A	Ambient Temp. (Power applied)	- 40		95	°C
T _{STG}	Storage Temp.	- 40		95	°C

3.0 Normal Operating Conditions

Symbol	Parameter	Min	Typ	Max	Units
V _{CC}	V _{CC} Supply Voltage	3.0	5	7.5	V
V _{CCN}	V _{CC} Supply Voltage Noise			50	mV _{P-P}
P _w	Module Power Dissipation (not including ANT power)		165		mW
T _{OP}	Operational Temp. (Power applied)	-40	25	85	°C
V _{BATT}	External supply voltage to RTC.	2.5	3.0	5.0	V
Bat-I	VBATT current consumption.	2.5V	0.7		uA
		3.5V	1.0		
		5.0V	1.8		
Apd	Power Down model Current			150	uA
ANT-V	Output to ANT DC voltage	V _{CC} -0.5		V _{CC}	V

4.0 Electrical Characteristics

Item	Symbol	Parameter	Min	Typ	Max	Units
V _{CC}		Module Supply Voltage	3.0	5.0	7.5	V
Data Input Voltage	V _{IH}	Input signal high level	1.5		V _{CC}	V
	V _{IL}	Input signal low level	-0.3		0.84	V
Data Output Voltage	V _{OH}	Output signal high level I _{OH} = 1mA	V _{CC} -0.5		V _{CC}	V
	V _{OL}	Output signal low level I _{OL} = 1 mA	0		.22V _{CC}	V

SPEC NO.	SP07CT99300-010	ISSUED DATE	2004/09/02	PUBLISHED BY
PRODUCT NAME	GPS RECEIVER/CT-9930	VERSION	01	
		PAGE	5/11	

5.0 Module Specification

Dimensions		50mm * 30mm * 13mm(L*W*H)
Satellite Tracking		12 Parallel channels
RF input	Center frequency	1575.42MHz L1 band, C/A code
	Characteristics impedance	50 ohm
	Signal sensitivity	-145 dBm (Searching Mode) -157 dBm (Tracking)
Positioning system	Default	WGS-84
	Software Selectable	All major coordinate systems
Positioning accuracy	Position	10 m CEP (50%)
	Velocity	0.2m/s (50%)
Follow-up performance	Acceleration	4g
Navigation Update Rate		Default 1 second (see 13.2.5)
Operation Temperature		- 40 ° C to 85 ° C
Storage Temperature		- 40 ° C to 95 ° C
Operating voltage		3.0 V...7.5 V (Linearly regulated)
Antenna supply		Same as board supply or Separate external supply (e.g. 5V)
Antenna		External active
Power drain		60 mA, 170 mW (Active antenna power not included)
I/O –port		asynchronous data I/O ports RTC Back-up battery input
Flash memory memory		8 Mbits of on-board volatile (Module firmware used 4Mbits ,remainder 4Mbits for user define)

SPEC NO.	SP07CT99300-010	ISSUED DATE	2004/09/02	PUBLISHED BY
PRODUCT NAME	GPS RECEIVER/CT-9930	VERSION	01	
		PAGE	6/11	

6.0 Time To First Fix (TTFF)

Typical Condition: 8 satellites in view + all previous conditions stand.

Hot Start (time, position, valid ephemeris, and valid almanac)	12 seconds
Warm Start (time, position, no ephemeris, and valid almanac)	35 seconds
Cold Start (no time & position, no ephemeris, and no almanac)	50 seconds

7.0 Module Interface

RF input connector	H.F.L (M)
I/O connector (Power supply, serial data)	Pin wafer
	11pin/1mm pitch /90/ (M)

8.0 Communication Specification

Communication method	Start-stop synchronization
Transfer rate input/output	2400/4800/9600/ 19200/115200bps (Default 4800, see 13.2)
Logic levels	TTL compatible
I/O code	ASCII
Communication format	Binary

SPEC NO.	SP07CT99300-010	ISSUED DATE	2004/09/02	PUBLISHED BY
PRODUCT NAME	GPS RECEIVER/CT-9930	VERSION	01	
		PAGE	7/11	

9.0 Recommended Antenna Specification

Antenna

Center frequency	1575.42MHz
Polarization	Right-handed circular polarization
Gain	-5dBi or more ($5^\circ < \text{Angle of elevation}$)
Axis ratio	3dB typical ($\text{Angle of elevation} = 90^\circ$)

Pre-amplifier

Gain	15~25dB (included antenna cable loss)
Noise figure (NF)	2.5dB or less

Overall Specification

Gain	17dBi or more ($\text{Angle of elevation} = 90^\circ$)
Output impedance	50 ohms
Output VSWR	2.0 or less
Supply voltage	GPS active Antenna's working voltage must match the VCC.
Maximum Current consumption	30mA

SPEC NO.	SP07CT99300-010	ISSUED DATE	2004/09/02	PUBLISHED BY
PRODUCT NAME	GPS RECEIVER/CT-9930	VERSION	01	
		PAGE	8/11	

10.0 Dimension

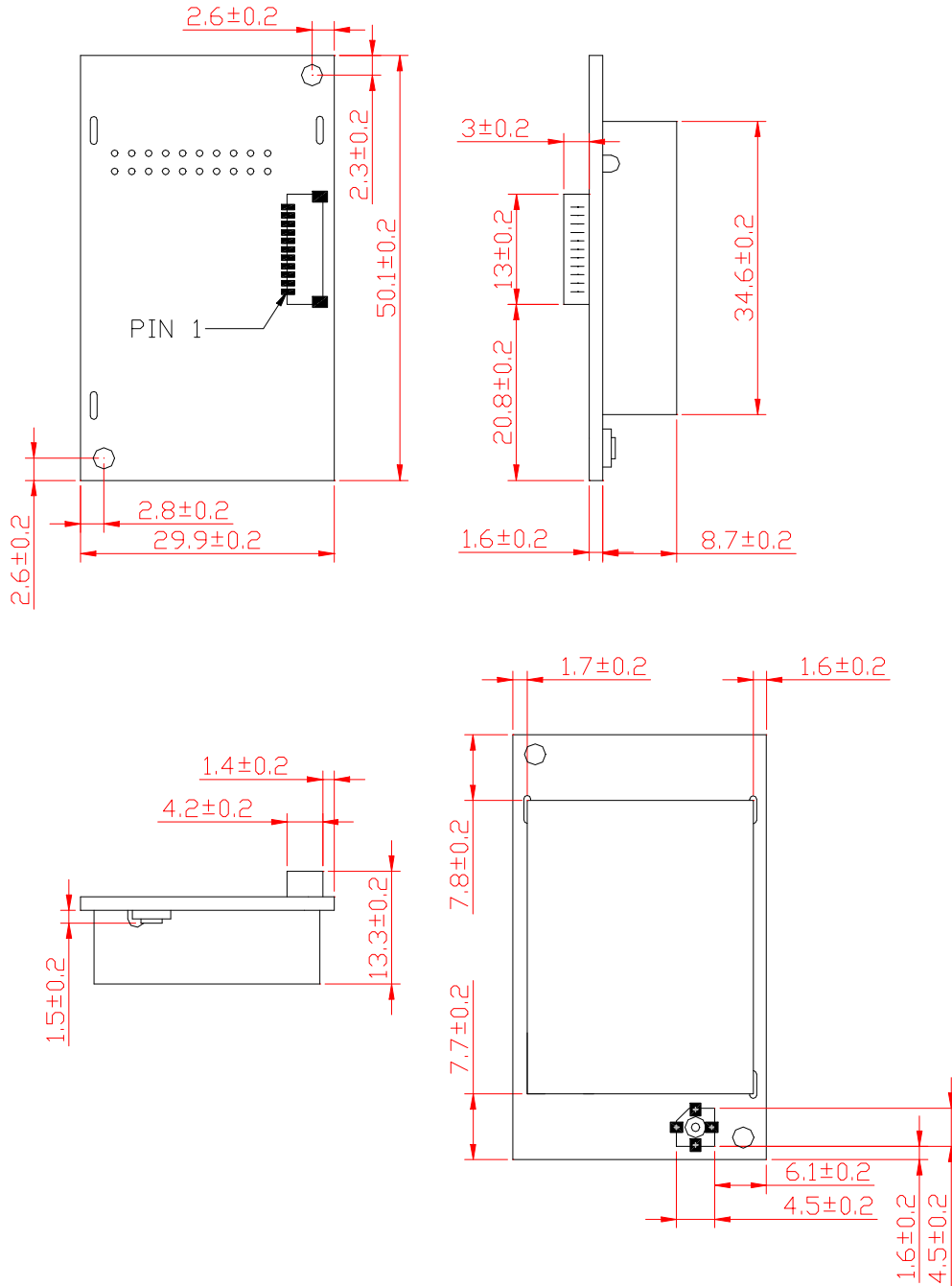

Unit of Measurement: mm
Error of Measurement: ±0.2

SPEC NO.	SP07CT99300-010	ISSUED DATE	2004/09/02	PUBLISHED BY
PRODUCT NAME	GPS RECEIVER/CT-9930	VERSION	01	
		PAGE	9/11	

Pin Configuration

Pin No.	Symbol	I/O	Description
1	GND	Ground	Power and signal ground
2	V-Battery	I	Battery Voltage input.
3	TXD	O	UART Port, Transmit Data output.
4	RXD0	I	UART Port, Receive Data input.
5	VCC	I	GPS Module & active ANT power input.
6	N.C		No connection.
7	N.C		No connection.
8	N.C		No connection.
9	N.C		No connection.
10	N.C		No connection.
11	GND	Ground	Power and signal ground

11.0GPS Receiver Module Configuration

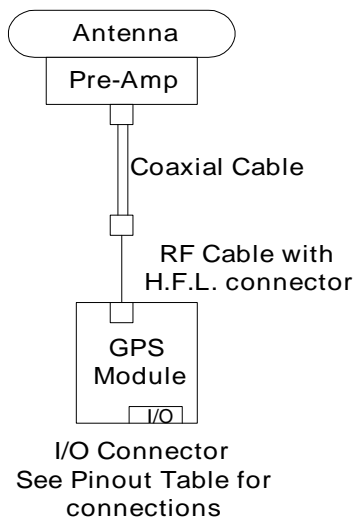

Configuration with Active Antenna

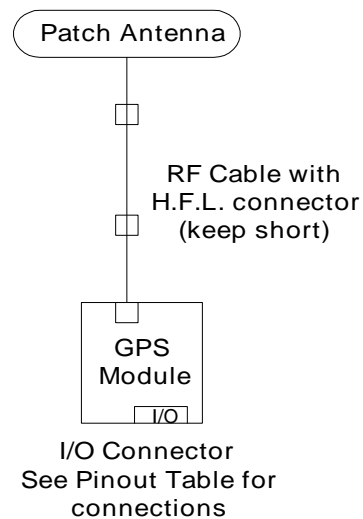



Configuration with Passive Antenna

Reset During Operation

SPEC NO.	SP07CT99300-010	ISSUED DATE	2004/09/02	PUBLISHED BY
PRODUCT NAME	GPS RECEIVER/CT-9930	VERSION	01	
		PAGE	10/11	

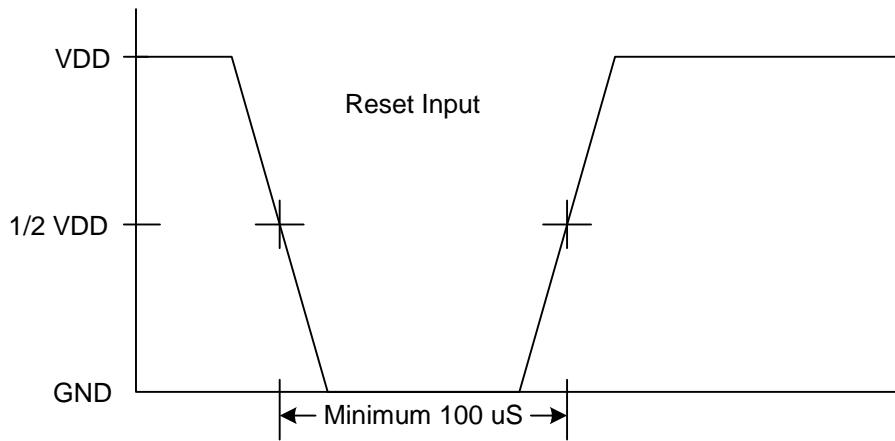
$V_{DD} = 3.0$ to $3.6V$, , temperature = -40 to $+85^{\circ}C$



SPEC NO.	SP07CT99300-010	ISSUED DATE	2004/09/02	PUBLISHED BY
PRODUCT NAME	GPS RECEIVER/CT-9930	VERSION	01	
		PAGE	11/11	

12.0 Reference

NMEA Commands:

Refer to document (AN07NMEA183-010)