

SPEC NO.	SP07CT55110-010	ISSUED DATE	2004/01/14	PUBLISHED BY
PRODUCT NAME	GPS RECEIVER/CT-5511	VERSION	d02	
		PAGE	2/11	

INDEX

Item No.	Contents	Page
1.0	Cautions	3
2.0	Absolute Maximum Rating	4
3.0	Normal operating Conditions	4
4.0	Module Specification	5
5.0	Time to First Fix (TTFF)	6
6.0	Module Interface	6
7.0	Communication Specification	6
8.0	Electrical Characteristics	7
9.0	Recommend Antenna Specifical	7
10.0	Dimension and Pin Definition	8
11.0	GPS Receiver Module Configuration	10
12.0	Reference	11

SPEC NO.	SP07CT55110-010	ISSUED DATE	2004/01/14	PUBLISHED BY
PRODUCT NAME	GPS RECEIVER/CT-5511	VERSION	d02	
		PAGE	3/11	

1.0 Cautions

GPS (Global Positioning System) is a satellite-based navigation system. In an unobstructed clear view of the sky, GPS works anywhere in the world, 24 hours a day.

GPS is developed and operated by the government of United States. Under the policy of the government, the degradation in accuracy shall occur without prior warnings, and sometimes satellites don't transmit signal due to adjustment, test, and orbital revision.

Please be aware that the performance of the GPS receiver module does not warrant against the above factors.

(Position Accuracy)

Position data and position accuracy are affected or degraded by the satellite geometry, electric magnetic interference, and multipath.

(Equipment)

The high frequency noise will interfere with signal receiving. The high frequency noise within the receiver frequency band, $1575\text{MHz} \pm 10\text{MHz}$, will affect the receiver quality. Also, because of the mixer and modulation, the low frequency noise will be increased by several times. If this increased frequency drops into the $1575\text{MHz} \pm 10\text{MHz}$ band, it will also affect the receiver quality.

Another warning should be notified. GPS receiver modules should not be placed close to heat and fans. Drastic changes in temperature will degrade the signal receiving strength even when operating within the operation temperature. Crystal and crystal oscillator on PCB ASSY should be kept away from the cooling fan.

(Power)

If the impedance of the power terminal is too high (power cable too thin and over 10 cm long), then S/N will be degraded. Please insert condenser (above $47 \mu\text{F}$) into cable terminal to remove ripple.

(Operation)

Static electricity will destroy IC and erase backup data. Wear anti static electricity bundle while you are using the GPS Receive Module).

Besides static electricity, plugging in or out the connector while power on will cause initialization. Make sure this is performed under power-off condition.

(Antenna)

In order to strengthen the sensitivity for car navigation, GPS antenna is suggested to mount on a flat place around $80 \times 80\text{mm}$.

(Warranty)

If the product fails within one year after the date of delivery while it has been used properly it will be replaced or repaired free of charge.

SPEC NO.	SP07CT55110-010	ISSUED DATE	2004/01/14	PUBLISHED BY
PRODUCT NAME	GPS RECEIVER/CT-5511	VERSION	d02	
		PAGE	4/11	

(Environmental conditions)

The product should be suitably installed or shielded so that it should not be affected by high frequency (1575.42MHz± 10MHz) noises from other devices like CPUs. Don't allow the airflow from the cooling fan to come directly to the quartz crystal oscillator in the receiver module.

2.0 Absolute Maximum Ratings

Note: This module is not intended to operate under the conditions listed in Absolute Maximum Ratings. Continuous operation under these conditions or exceeding the maximum ratings may result in permanent damage to this device.

Symbol	Parameter	Min	Typ	Max	Units
Vcc	Module Supply Voltage	- 0.3	3.3	3.9	V
V _I	Input Voltage	- 0.3		Vcc	V
T _A	Ambient Temp. (Power applied)	- 40		95	°C
T _{STG}	Storage Temp.	- 40		95	°C

3.0 Normal Operating Conditions

Symbol	Parameter	Min	Typ	Max	Units
Vcc	3.3V Module Supply Voltage	3.0	3.3	3.6	V
Vccn	Supply Voltage Noise			50	mV _{P-P}
Pw	Module Power Dissipation		165		mW
Top	Operational Temp. (Power applied)	-40	25	85	°C
Vbatt	Keep Internal RTC running	2.5	3.0	5.0	V

SPEC NO.	SP07CT55110-010	ISSUED DATE	2004/01/14	PUBLISHED BY
PRODUCT NAME	GPS RECEIVER/CT-5511	VERSION	d02	
		PAGE	5/11	

4.0 Module Specification

Dimensions		35.1mm*27.3mm*7.5mm(L*W*H)
Satellite Tracking		12 Parallel channels
RF input	Center frequency Characteristics impedance Signal sensitivity	1575.42MHz L1 band, C/A code 50 ohm -145 dBm (Searching Mode) -157 dBm (Tracking)
Positioning system	Default Software Selectable	WGS-84 All major coordinate systems
Positioning accuracy	Position Velocity	10 m CEP (50%) 0.2m/s (50%)
Follow-up performance	Acceleration	4g
Navigation Update Rate		Default 1 second (see 13.2.5)
Operation Temperature		-40° C to 85° C
Storage Temperature		-40° C to 95° C
Operating voltage		3.0 V..3.6 V (Linearly regulated)
Antenna supply		Same as board supply or Separate external supply (e.g. 5V)
Antenna		External, passive or active
Power drain		50 mA, 165 mW @3.3V (Active antenna power not included)
I/O -port		Dual asynchronous data ports 10 PINs GPIO 1PPS output
Flash memory memory		8 Mbits of on-board volatile (Module firmware used 4Mbits ,remainder 4Mbits for user define)

SPEC NO.	SP07CT55110-010	ISSUED DATE	2004/01/14	PUBLISHED BY
PRODUCT NAME	GPS RECEIVER/CT-5511	VERSION	d02	
		PAGE	7/11	

8.0 Electrical Characteristics

Item	Symbol	Parameter	Min	Typ	Max	Units
Vcc		Module Supply Voltage	3.0	3.3	3.6	V
Input Voltage	VIH	Input signal high level	.7(Vcc-0.3)		Vcc	V
	VIL	Input signal low level	-0.3		.3(Vcc-0.3)	V
Output Voltage	VOH	Output signal high level IOH = 1mA	.8(Vcc-0.3)		Vcc	V
	VOL	Output signal low level IOL = 1 mA	0		.22Vcc	V

9.0 Recommended Antenna Specification

Antenna

Center frequency	1575.42MHz
Polarization	Right-handed circular polarization
Gain	-5dBi or more ($5^\circ < \text{Angle of elevation}$)
Axis ratio	3dB typical ($\text{Angle of elevation} = 90^\circ$)

Pre-amplifier

Gain	15~25dB (included antenna cable loss)
Noise figure (NF)	2.5dB or less

Overall Specification

Gain	17dBi or more ($\text{Angle of elevation} = 90^\circ$)
Output impedance	50 ohms
Output VSWR	2.0 or less
Supply voltage	External supply, according to antenna requirement Internal supply (Pin7 and Pin9 Short) 3V
Maximum Current consumption	30mA

SPEC NO.	SP07CT55110-010	ISSUED DATE	2004/01/14	PUBLISHED BY
PRODUCT NAME	GPS RECEIVER/CT-5511	VERSION	d02	
		PAGE	8/11	

10.0 Dimension

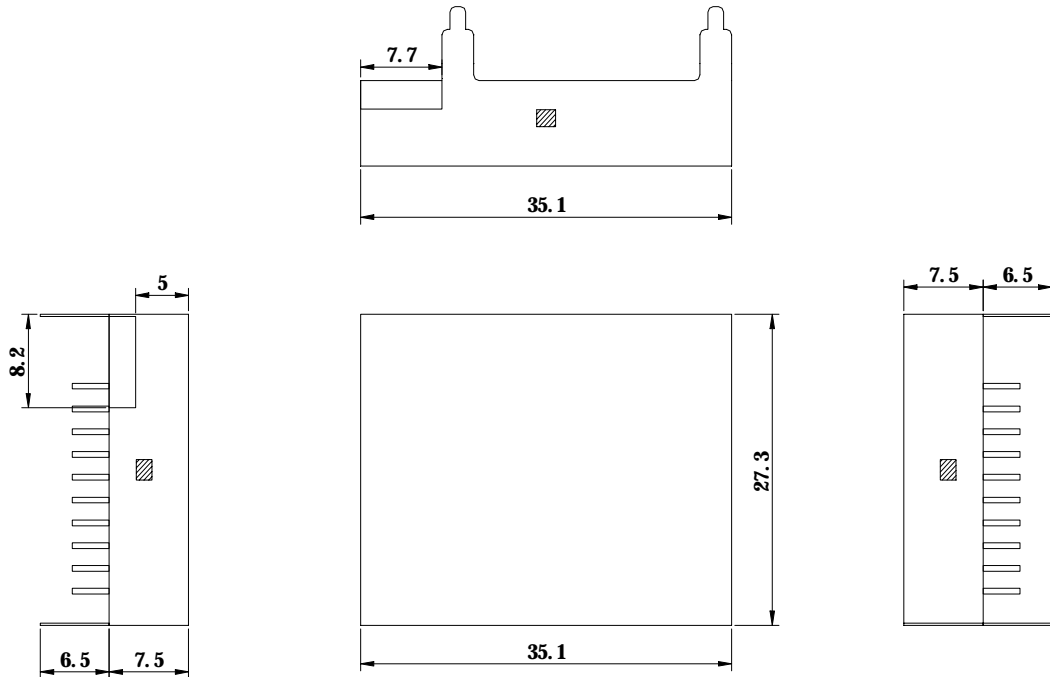

TOP VIEW

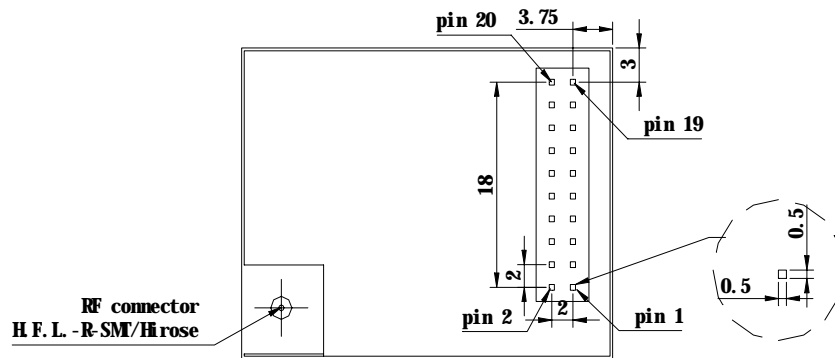
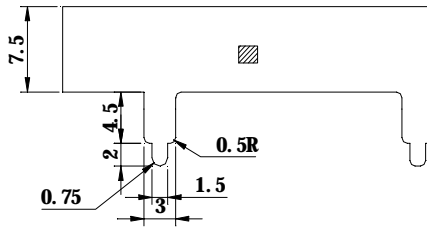

BOTTON VIEW

Unit of Measurement: mm
 Error of Measurement: ± 0.2

SPEC NO.	SP07CT55110-010	ISSUED DATE	2004/01/14	PUBLISHED BY
PRODUCT NAME	GPS RECEIVER/CT-5511	VERSION	d02	
		PAGE	9/11	

Pin Configuration

Pin No.	Symbol	I/O	Description
1	GPIO[3]	I/O	General Purpose I/O
2	GPIO[4]	I/O	General Purpose I/O
3	GPIO[5]	I/O	General Purpose I/O
4	GPIO[6]	I/O	General Purpose I/O
5	GND	Ground	Power and signal ground
6	V-Battery	I	At Power-off Mode to keep RTC running.
7	VANT	I	Antenna bias DC Power Supply
8	RXD0	I	UART Port 0, Receive Data
9	VCC	I	Main power input.
10	RESET	I	Module reset input.
11	TXD1	O	UART Port 1, Transmit Data
12	RXD1	I	UART Port 1, Receive Data
13	1 PPS	O	1 PPS signal output
14	TXD0	O	UART Port 0, Transmit Data
15	GPIO[11]	I/O	External Wake-up, Interrupt input
16	GND	Ground	Power and signal ground
17	GPIO[0]	I/O	General Purpose I/O
18	GPIO[1]	I/O	General Purpose I/O
19	GPIO[15]	I/O	Boot Mode select, 1 : FLASH, 0 : UART/SPI
20	GPIO[2]	I/O	General Purpose I/O

SPEC NO.	SP07CT55110-010	ISSUED DATE	2004/01/14	PUBLISHED BY
PRODUCT NAME	GPS RECEIVER/CT-5511	VERSION	d02	
		PAGE	10/11	

11.0 GPS Receiver Module Configuration

Configuration with Active Antenna

Configuration with Passive Antenna

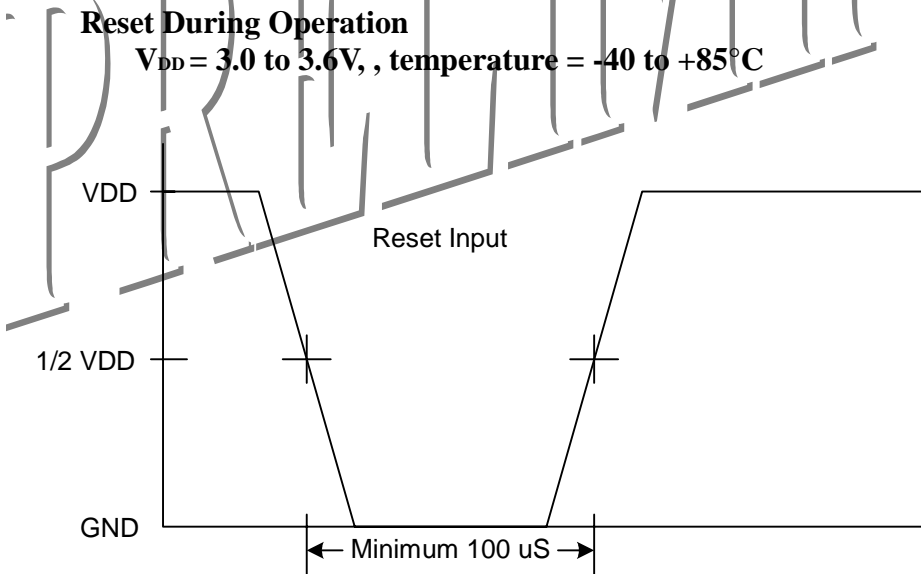
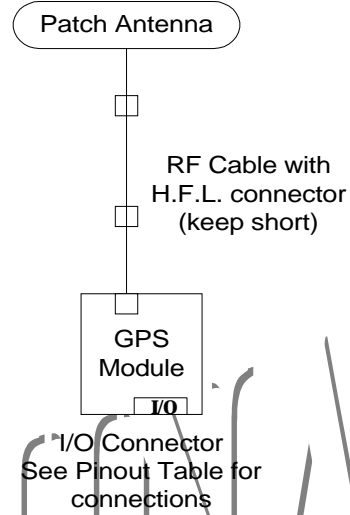
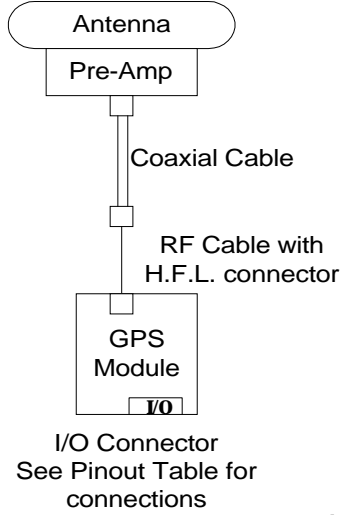

SPEC NO.	SP07CT55110-010	ISSUED DATE	2004/01/14	PUBLISHED BY
PRODUCT NAME	GPS RECEIVER/CT-5511	VERSION	d02	
		PAGE	11/11	

12.0 Reference

NMEA Commands:

Refer to document (AN07NMEA183-010)

PRELIMINARY